

**Preliminary DATA SHEET**

**CFORTH-SFP-LX-D**

***1.25GBd SFP (Small Form Pluggable) Long Wavelength (1310nm) Transceiver***

**CFORTH-SFP-LX-D Overview**

CFORTH-SFP-LX-D SFP optical transceivers are based on Gigabit Ethernet IEEE 802.3 standard and Fiber Channel FC-PI Rev.5.0 and provide a quick and reliable interface for the GE/FC application. The Digital diagnostics functions are available via 2-wire serial bus specified in the SFP MSA. In addition, they comply with the Small Form Factor Pluggable Multi Sourcing Agreement (MSA) and SFF-8472.

**Product Features**

- Up to 1.25 GBd bi-directional data links
- Compliant with IEEE 802.3z Gigabit Ethernet and 1000BASE-LX
- Compliant with SFP MSA
- Hot-pluggable SFP footprint
- 1310nm Fabry-Perot laser transmitter
- Duplex LC connector
- Built-in digital diagnostic functions
- Up to 10km on 9/125um SMF
- Single power supply 3.3V
- RoHS Compliance
- Class 1 laser product complies with EN 60825-1
- Operating temperature range: -5°C to 85°C.

**Applications**

- 1.25 GBd Gigabit Ethernet
- 1.063 GBd Fiber Channel

**Ordering Information**

---

<i>Part Number</i>	<i>Description</i>
CFORTH-SFP-LX-D	GE/FC SFP 1310nm LC Connectors 10km on SMF, with DOM function.

---

**General Specifications**

<i>Parameter</i>	<i>Symbol</i>	<i>Min</i>	<i>Typ</i>	<i>Max</i>	<i>Unit</i>	<i>Remarks</i>
Data Rate	<i>DR</i>		1.25 1.062		GBd	IEEE 802.3 FC-PI-2 Rev 5
Bit Error Rate	<i>BER</i>			$10^{-12}$		
Operating Temperature	<i>T<sub>OP</sub></i>	- 5		85	°C	Case temperature
Storage Temperature	<i>T<sub>STO</sub></i>	- 40		85	°C	Ambient temperature
Supply Current	<i>I<sub>S</sub></i>		175	300	mA	For electrical power interface
Input Voltage	<i>V<sub>CC</sub></i>	3	3.3	3.6	V	
Maximum Voltage	<i>V<sub>MAX</sub></i>	- 0.5		4	V	For electrical power interface

**Optical Characteristics – Transmitter***V<sub>CC</sub>=3V to 3.6V, T<sub>C</sub>=-5°C to 85°C*

<i>Parameter</i>	<i>Symbol</i>	<i>Min</i>	<i>Typ</i>	<i>Max</i>	<i>Unit</i>	<i>Remarks</i>
Output Optical Power	<i>P<sub>TX</sub></i>	- 9.5		- 3	dBm	Class 1 Product
Optical Center Wavelength	<i>λ<sub>C</sub></i>	1260		1355	nm	
Optical Modulation Amplitude	<i>OMA</i>	174			uW	Equivalent extinction ratio specification for FC
Extinction Ratio	<i>ER</i>	9			dB	
Spectral Width (RMS)	<i>Δλ</i>			3	nm	
Optical Rise/Fall Time (20% - 80%)	<i>T<sub>RF,IN</sub></i>		150	260	ps	
Relative Intensity Noise	<i>RIN</i>			- 120	dB/Hz	
Deterministic Jitter Contribution	<i>TX_ΔDJ</i>		20	60	ps	
Total Jitter Contribution	<i>TX_ΔTJ</i>		50	120	ps	

**Optical Characteristics – Receiver***V<sub>CC</sub>=3V to 3.6V, T<sub>C</sub>=-5°C to 85°C*

<i>Parameter</i>	<i>Symbol</i>	<i>Min</i>	<i>Typ</i>	<i>Max</i>	<i>Unit</i>	<i>Remarks</i>
Optical Receiver Power	<i>P<sub>RX</sub></i>	- 20		- 3	dBm	Average
Optical Center Wavelength	<i>λ<sub>C</sub></i>	1265		1600	nm	
Receiver Sensitivity @ 1.063GBd	<i>R<sub>X,SEN1</sub></i>			- 22	dBm	FC-PI-2 Rev.5
Receiver Sensitivity @ 1.25GBd	<i>R<sub>X,SEN2</sub></i>			- 22	dBm	IEEE 802.3
Stressed Rx Sens @ 1.25GBd				- 14.5	dBm	IEEE 802.3
Optical Return Loss	<i>ORL</i>	12			dB	
Receiver Electrical 3dB Upper cutoff frequency				1500	MHz	
Loss of Signal-Asserted	<i>P<sub>LOS,A</sub></i>	- 30			dBm	
Loss of Signal-Deasserted	<i>P<sub>LOS,D</sub></i>			- 22	dBm	
Loss of Signal-Hysteresis		0.5			dB	

**Electrical Characteristics – Transmitter***V<sub>CC</sub>=3V to 3.6V, T<sub>C</sub>=-5°C to 85°C*

<b>Parameter</b>	<b>Symbol</b>	<b>Min</b>	<b>Typ</b>	<b>Max</b>	<b>Unit</b>	<b>Remarks</b>
Input differential impedance	$R_{IN}$		100		$\Omega$	Non condensing
Single ended data input swing	$V_{IN\_PP}$	250		1200	mV	
Transmit disable voltage	$V_D$	$V_{CC}-1.3$		$V_{CC}$	V	
Transmit enable voltage	$V_{EN}$	$V_{EE}$		$V_{EE}+0.8$	V	
Transmit disable assert time				10	us	

**Electrical Characteristics – Receiver***V<sub>CC</sub>=3V to 3.6V, T<sub>C</sub>=-5°C to 85°C*

<b>Parameter</b>	<b>Symbol</b>	<b>Min</b>	<b>Typ</b>	<b>Max</b>	<b>Unit</b>	<b>Remarks</b>
Single ended data output swing	$V_{OUT\_PP}$	300	400	800	mV	
Data output rise/fall time (20%-80%)	$T_R$			300	ps	
LOS Fault	$V_{LOS\_Fault}$	$V_{CC}-0.5$		$V_{CC\_HOST}$	V	
LOS Normal	$V_{LOS\_normal}$	$V_{EE}$		$V_{EE}+0.5$	V	

**Digital Diagnostic Functions**

CFORTH-SFP-LX-D support the 2-wire serial communication protocol as defined in the SFP MSA. Digital diagnostic information are accessible over the 2-wire interface at the address 0xA2. Digital Diagnostics for CFORTH-SFP-LX-D are internally calibrated by default. A micro controller unit inside the transceiver gathers the monitoring information and reports the status of transceiver.

**Transceiver Temperature**, internally measured, represented as a 16 bit signed twos complement value in increments of 1/256 degrees Celsius, Temperature accuracy is better than  $\pm 3$  degrees Celsius over specified operating temperature and voltage.

**Transceiver Supply Power**, internally measured, represented as a 16 bit unsigned integer with the voltage defined as the full 16 bit value (0 – 65535) with LSB equal to 100  $\mu$ Volt, yielding a total range of 0 to +6.55 Volts.

**Transceiver TX bias current**, internally measured, represented as a 16 bit unsigned integer with the current defined as the full 16 bit value (0 – 65535) with LSB equal to 2  $\mu$ A, yielding a total range of 0 to 131mA. Accuracy is better than  $\pm 10\%$  over specified operating temperature and voltage.

**Transceiver TX output power**, internally measured, represented as a 16 bit unsigned integer with the power defined as the full 16 bit value (0 – 65535) with LSB equal to 0.1  $\mu$ W. Data is assumed to be based on measurement of laser monitor photodiode current. Accuracy is better than  $\pm 3$ dB over specified temperature and voltage. Data is not valid when the transmitter is disabled.

**Transceiver RX received optical power**, internally measured, represented as a 16 bit unsigned integer with the power defined as the full 16 bit 35 value (0 – 65535) with LSB equal to 0.1  $\mu$ W. Accuracy is better than  $\pm 3$ dB over specified temperature and voltage.

## Block Diagram of Transceiver

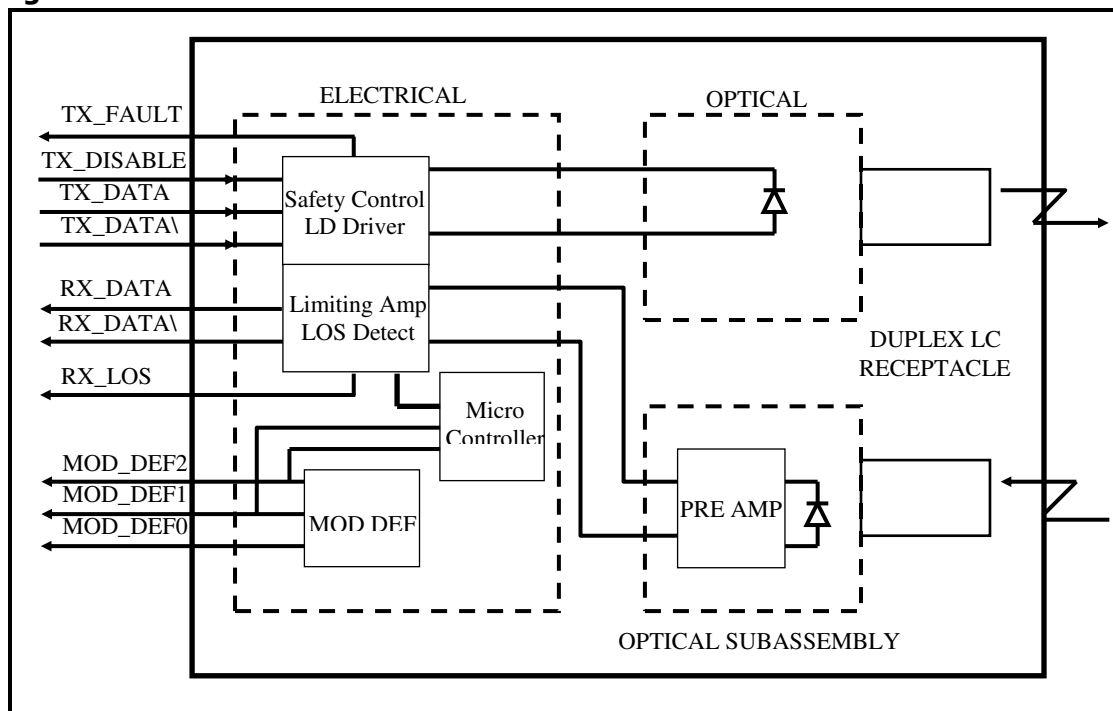

### Transmitter Section

The FP driver accept differential input data and provide bias and modulation currents for driving a laser. An automatic power-control (APC) feedback loop is incorporated to maintain a constant average optical power. 1310 nm FP in an eye safe optical subassembly (OSA) mates to the fiber cable.

### TX\_DISABLE

The TX\_DISABLE signal is high (TTL logic "1") to turn off the laser output. The laser will turn on within 1ms when TX\_DISABLE is low (TTL logic "0").

### TX\_FAULT

When the TX\_FAULT signal is high, output indicates a laser fault of some kind. Low indicates normal operation.

### Receiver Section

The receiver utilizes a PIN detector integrated with a trans-impedance preamplifier in an OSA. This OSA is connected to a Limiting Amplifier which providing post-amplification quantization, and optical signal detection. The limiting Amplifier is AC-coupled to the transimpedance amplifier, with internal 100Ω differential termination.

### Receive Loss (RX\_LOS)

The RX\_LOS is high (logic "1") when there is no incoming light from the companion transceiver. This signal is normally used by the system for the diagnostic purpose. The signal is operated in TTL level.

### Controller Section

The micro controller unit monitors the operation information of LD driver and Limiting Amplifier. And report these status to the customer.

**Dimensions**

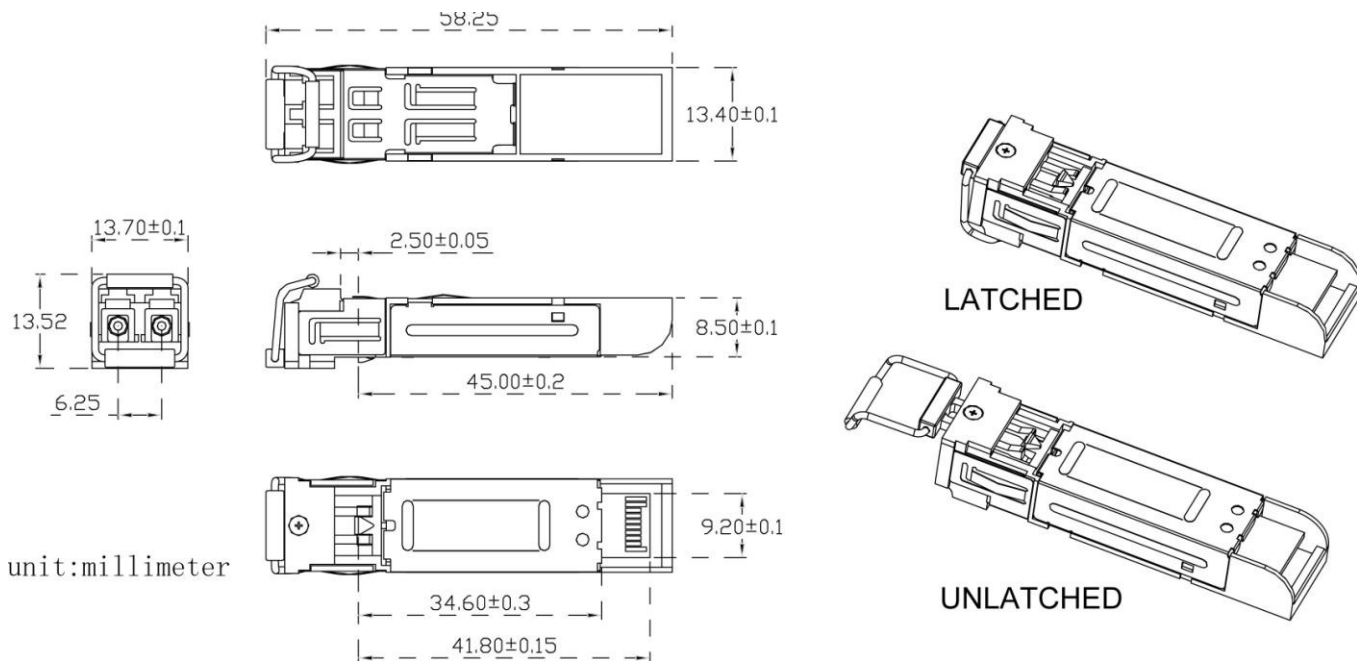

unit:millimeter

**ALL DIMENSIONS ARE ±0.2mm UNLESS OTHERWISE SPECIFIED  
UNIT: mm**

PCB Layout Recommendation

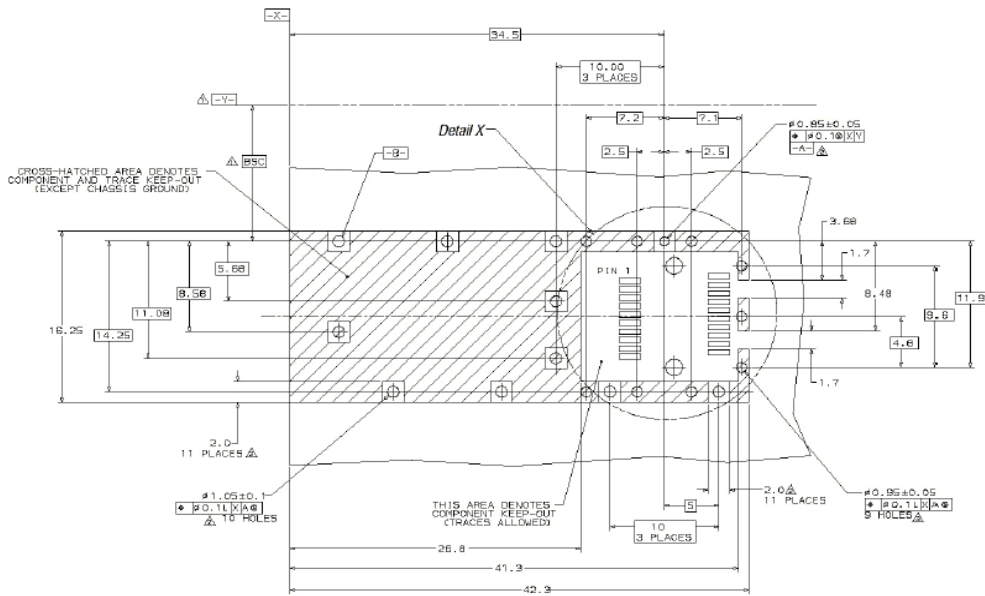

△ Datum and Basic Dimension Established by Customer

△ Rads and Vias are Chassis Ground, 11 Places

△ Through Holes are Unplated

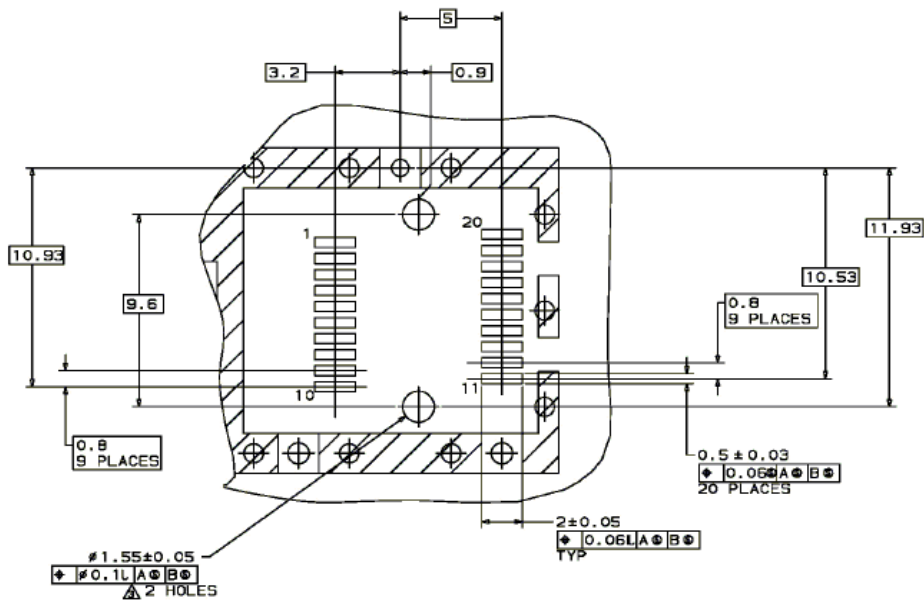

## Electrical Pad Layout

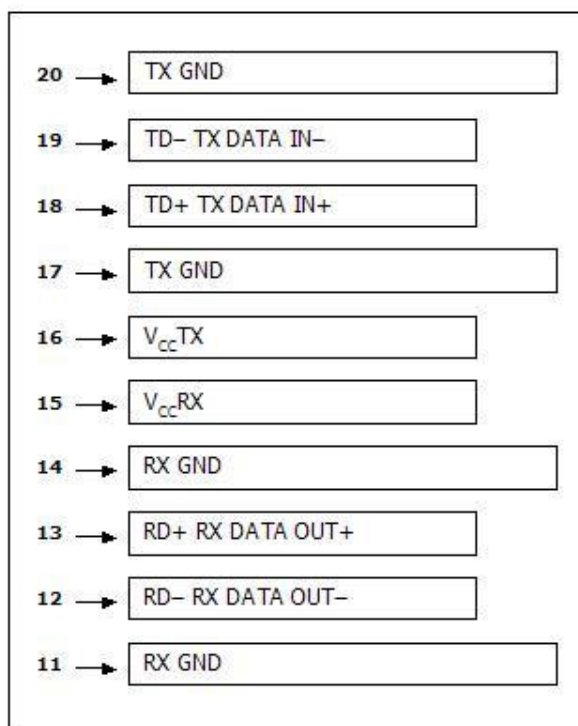
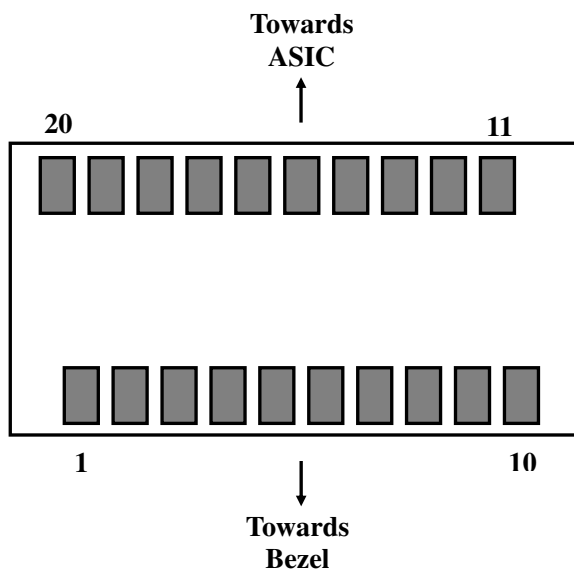

Top of Board

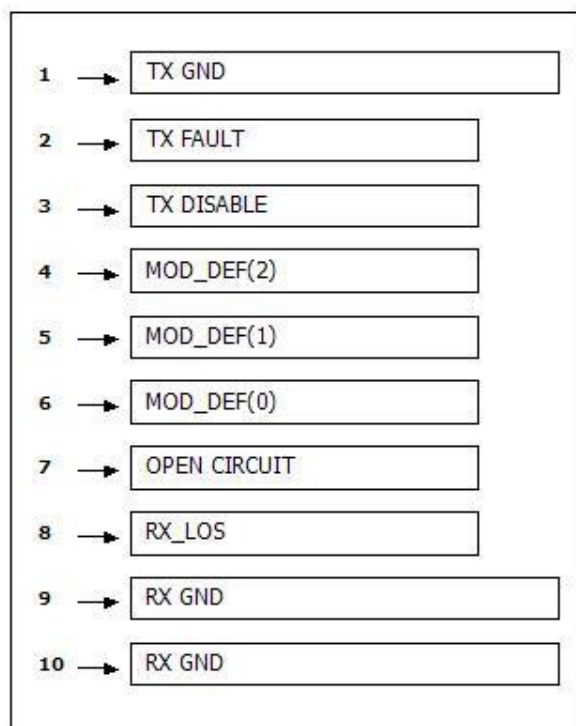

Bottom of Board



**Pin Assignment**

<b>PIN #</b>	<b>Symbol</b>	<b>Description</b>	<b>Remarks</b>
1	V <sub>EET</sub>	Transmitter ground (common with receiver ground)	Circuit ground is isolated from chassis ground
2	T <sub>FAULT</sub>	Transmitter Fault. Not supported	
3	T <sub>DIS</sub>	Transmitter Disable. Laser output disable on high or open	Disabled: T <sub>DIS</sub> >2V or open Enabled: T <sub>DIS</sub> <0.8V
4	MOD_DEF (2)	Module Definition 2. Data line for serial ID	Should Be pulled up with 4.7k – 10k ohm on host board to a voltage between 2V and 3.6V
5	MOD_DEF (1)	Module Definition 1. Clock line for serial ID	
6	MOD_DEF (0)	Module Definition 0. Grounded within the module	
7	Rate Select	No connection required	
8	LOS	Loss of Signal indication. Logic 0 indicates normal operation	LOS is open collector output
9	V <sub>EER</sub>	Receiver ground (common with transmitter ground)	
10	V <sub>EER</sub>	Receiver ground (common with transmitter ground)	Circuit ground is isolated from chassis ground
11	V <sub>EER</sub>	Receiver ground (common with transmitter ground)	
12	RD–	Receiver Inverted DATA out. AC coupled	
13	RD+	Receiver Non-inverted DATA out. AC coupled	
14	V <sub>EER</sub>	Receiver ground (common with transmitter ground)	Circuit ground is isolated from chassis ground
15	V <sub>CCR</sub>	Receiver power supply	
16	V <sub>CCT</sub>	Transmitter power supply	
17	V <sub>EET</sub>	Transmitter ground (common with receiver ground)	Circuit ground is connected to chassis ground
18	TD+	Transmitter Non-Inverted DATA in. AC coupled	
19	TD–	Transmitter Inverted DATA in. AC coupled	
20	V <sub>EET</sub>	Transmitter ground (common with receiver ground)	Circuit ground is connected to chassis ground

**References**

1. IEEE standard 802.3. IEEE Standard Department, 2002.
2. Small Form Factor Pluggable (SFP) Transceiver Multi-Source Agreement (MSA), September 2000.
3. Fiber Channel Draft Physical Interface Specification (FC-PI-2 Rev.5).
4. Digital Diagnostics Monitoring Interface for Optical Transceivers – SFF-8472.
5. Fiber Channel Physical and Signaling Interface (FC-PH/PH2/PH3).