

Preliminary DATA SHEET

CFORTH-QSFP-4x10G-PLR4

40Gb/s QSFP+ PSM4 10km Optical Transceiver

CFORTH-QSFP-4x10G-PLR4 Overview

CFORTH-QSFP-4x10G-PLR4 QSFP+ 40Gbps PSM4 optical transceivers are based on Ethernet IEEE 802.3ba standard and SFF-8436 standard. The QSFP+ full-duplex optical module offers 4 independent transmit and receive channels, each capable of 10.3125Gbps operation for an aggregate data rate of 41.25 Gbps 10km of single mode fiber. An optical fiber ribbon cable with an MPO/MTP connector can be plugged into the QSFP module receptacle.

Product Features

- Compliant with QSFP+ MSA (SFF-8436)
- Up to 11.2Gbps data rate per channel
- MPO optical connector
- Built-in digital diagnostic functions
- Up to 10km transmission on SMF
- Maximum 2W operation power
- RoHS-6 Compliant
- Operating temperature range: 0°C to 70°C

Applications

- 40G Ethernet
- Infiniband interconnects

Ordering Information

Part Number	Description	Color on Clasp
CFORTH-QSFP-4x10G-PLR4	40G QSFP+ PSM4 1310nm MPO Connectors, up to 10km on SMF, with DOM function	Blue

General Specifications

Parameter	Symbol	Min	Typ	Max	Unit	Remarks
Bit Error Rate	BER			10^{-12}		
Operating Temperature	T_C	0		70	°C	1
Storage Temperature	T_{STO}	-40		85	°C	2
Supply Current	I_{CC}			600	mA	
Input Voltage	V_{CC}	3.14	3.3	3.46	V	
Maximum Voltage	V_{MAX}	0		3.8	V	3
Power Consumption	V_{CC}			2	W	

Notes:

1. Case temperature
2. Ambient temperature
3. For electrical power interface

Link Distances

Data Rate	Fiber Type	Distance Range (km)
40 Gb/s	9/125um SMF	10

Optical – Characteristics – Transmitter

Parameter	Symbol	Min	Typ	Max	Unit	Remarks
Average Launch Power(Each Lane)	P_{TX}	-8.2		0.5	dBm	
Optical Center Wavelength	λ_C	1260		1360	nm	
Optical Modulation Amplitude(Each Lane)	OMA	-5.2		2.0	dB	
Extinction Ratio	ER	3.5			dB	
Side Mode Suppression Ratio	SMSR	30			dB	
Relative Intensity Noise	RIN			-128	dB/Hz	
Optical Return Loss Tolerance	TOL			12	dB	
Launch Power of OFF Transmitter(each lane)	P_{OUT_OFF}			-30	dBm	

Optical – Characteristics – Receiver

Parameter	Symbol	Min	Typ	Max	Unit	Remarks
Optical Center Wavelength	λ_C	1260		1360	nm	
Optical Input Power(each lane)	P_{RX}			0.5	dBm	1
Damage Threshold	P	3			dBm	
Receiver Sensitivity (OMA)(each Lane)	R_{X_SEN1}			-12.6	dBm	
LOS Assert	LOS_A	-30			dBm	
LOS De-Assert	LOS_D			-15	dBm	
LOS Hysteresis	LOS_H	0.5		6	dB	

Notes:

1. Average, Informative

Electrical – Characteristics – Transmitter

Parameter	Symbol	Min	Typ	Max	Unit	Remarks
Input differential impedance	R _{IN}	90	100	110	Ω	
Differential data input swing	V _{IN_PP}	200		800	mV	
TP1/TP1a Interface	Compliant to IEEE802.3ba XLPPI					

Electrical – Characteristics – Receiver

Parameter	Symbol	Min	Typ	Max	Unit	Remarks
Output differential impedance	R _{OUT}	90	100	110	Ω	
Differential data output swing	V _{OUT_PP}	400	600	850	mV	
TP4 Interface	Compliant to IEEE802.3ba XLPPI					

Dimensions

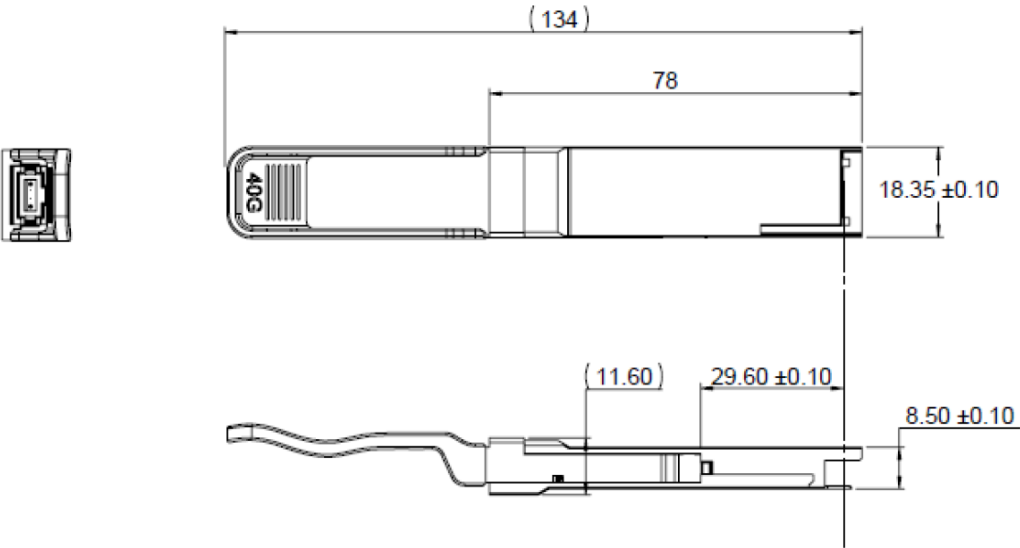

ALL DIMENSIONS ARE ±0.2mm UNLESS OTHERWISE SPECIFIED
UNIT: mm

Electrical Pad Layout

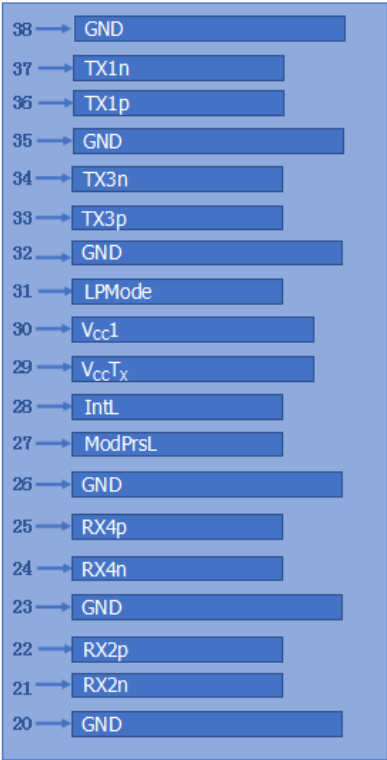

Top Board

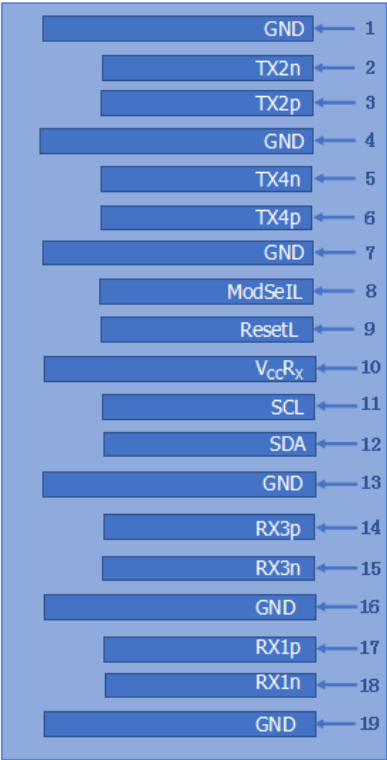

Bottom Board

Pin Assignment

PIN #	Symbol	Description	Remarks
1	GND	Ground	5
2	Tx2n	Transmitter Inverted Data Input	
3	Tx2p	Transmitter Non-Inverted Data Input	
4	GND	Ground	5
5	Tx4n	Transmitter Inverted Data Input	
6	Tx4p	Transmitter Non-Inverted Data Input	
7	GND	Ground	5
8	ModSelL	Module Insertion Indicator Pin	1
9	ResetL	Module Reset	2
10	V _{cc} R _X	+3.3V Power Supply Receiver	
11	SCL	2-wire serial interface clock	
12	SDA	2-wire serial interface data	
13	GND	Ground	5
14	Rx3p	Receiver Non-Inverted Data Output	
15	Rx3n	Receiver Inverted Data Output	
16	GND	Ground	5
17	Rx1p	Receiver Non-Inverted Data Output	
18	Rx1n	Receiver Inverted Data Output	
19	GND	Ground	5
20	GND	Ground	5
21	Rx2n	Receiver Inverted Data Output	
22	Rx2p	Receiver Non-Inverted Data Output	
23	GND	Ground	5
24	Rx4n	Receiver Inverted Data Output	
25	Rx4p	Receiver Non-Inverted Data Output	
26	GND	Ground	5
27	ModPrsL	Module Present	3
28	IntL	Interrupt	4
29	V _{cc} T _X	+3.3V Power Supply transmitter	
30	V _{cc} 1	+3.3V Power Supply	
31	LPMMode	Low Power Mode	5
32	GND	Ground	5
33	Tx3p	Transmitter Non-Inverted Data Input	
34	Tx3n	Transmitter Inverted Data Input	

35	GND	Ground	5
36	Tx1p	Transmitter Non-Inverted Data Input	
37	Tx1n	Transmitter Inverted Data Input	
38	GND	Ground	5

Notes:

1. ModSelL is the input pin. The module responds to 2-wire serial communication commands when it is held low by the host. ModSelL allows multiple QSFP modules to be used on a single 2-wire interface bus. If ModSelL is High, the module will not respond to any 2-wire interface communication from the host. ModSelL has internal pull-up resistors in the module
2. The module restart pin, when the low level on the ResetL pin lasts longer than the minimum pulse length, resets the module and restores all user modules to their default state. When performing reset device, the host should ignore all status bits. Until the module reset interrupt is completed, please note that during hot plugging, the module will issue this information to complete the reset interrupt without resetting
3. This pin is active high, indicating that the module is running under a low power module.
4. IntL is the output pin, which is the open collector output and must be pulled up to Vcc on the motherboard. When it is low, it indicates that the module may malfunction. The host uses a 2-wire serial interface to identify the interrupt source
5. Circuit ground is internally isolated from chassis ground.

References

1. IEEE standard 802.3ba. IEEE Standard Department, 2010.
2. QSFP+ 10Gbs 4X PLUGGABLE TRANSCEIVER SFF-8436